



September 13, 2010

MEMORANDUM FOR: JPA Liaisons

SUBJECT: Equipment Safety Data Sheets

It was brought to my attention by a board member that his district was in need of a source to supply safety parts for older machinery and equipment.

The result of that inquiry is the enclosed booklet entitled, **Equipment Safety Data Sheets**. This information will be useful to supervisors in the transportation, grounds, and maintenance departments and may also be utilized by shop teachers.

If you need additional copies, or have any questions, please contact me.

Henry Brock
Risk Manager

EQUIPMENT SAFETY DATA SHEETS



FRESNO COUNTY

SELF INSURANCE GROUP

OSS
ORGANIZATION OF
SELF-INSURED SCHOOLS

EQUIPMENT SAFETY DATA SHEETS

The purpose of the equipment safety data sheets is threefold:

1. Provide the information necessary to conduct a safety review of each piece of equipment in district maintenance, grounds and transportation shops. The data sheets may also be used in student shops/labs,
2. Provide guidance for ordering inoperative and missing safety equipment, and
3. Where necessary, provide a source for upgrading safety features.

Process:

1. Identify the appropriate sheet for the equipment being evaluated.
2. Complete the requested information at the top of the sheet.
3. Answer the questions.
4. If safety replacements or upgrades are necessary, take a picture of each of the four sides of the equipment from a distance to show the entire machine from its mount at the floor to the top of the machine and additional close-up pictures of each deficiency.
5. Contact **ReiTech Corporation**, 240 Shumway St., South, Suite 200, Shakopee, MN 55379, 952-895-6161, www.reitech.com to order safety items.



TABLE OF CONTENTS

SURVEY COVER PAGE	1
DISTRICT SURVEY COVER PAGE	2
BUFFING/POLISHING MACHINE SURVEY	3
DRILL PRESS SURVEY	4
PEDESTAL OR BENCH GRINDER SURVEY	5
WOOD TURNING LATHE SURVEY	6
WOOD JOINTER SURVEY	7
METAL TURNING LATHE SURVEY	8
HORIZONTAL MILLING MACHINE SURVEY	9
VERTICAL METAL CUTTING MILL SURVEY	10
POWER HYDRAULIC PRESS SURVEY	11
MANUAL HYDRAULIC PRESS SURVEY	12
WOOD PLANER/SURFACER SURVEY	13
BELT SANDER SURVEY	14
EDGE BELT SANDER SURVEY	15
VERTICAL SPINDLE SHAPER SURVEY	16
DRUM / SPINDLE SANDER SURVEY	17
BELT AND DISC SANDER SURVEY	18
DISC SANDER SURVEY	19
METAL CUTTING BAND SAW SURVEY (WITH BAND WELDER)	20
WOOD CUTTING BAND SAW SURVEY	21
HORIZONTAL METAL BAND SAW SURVEY	22
ABRASIVE METAL CUTTING CHOP SAW SURVEY	23
ELECTRIC MITER SAW SURVEY	24
PANEL SAW SURVEY	25
RADIAL ARM SAW SURVEY	26
SCROLL SAW SURVEY	27
TABLE SAW SURVEY	28
RESISTANCE SPOT WELDER SURVEY	29
SURFACE GRINDER SURVEY	30
TIRE BALANCER SURVEY	31
TIRE CHANGER SURVEY	32
VALVE GRINDER SURVEY	33
BRAKE LATHE SURVEY	34
MACHINE TYPE	35

District Survey Cover Page (2)

Building #4

Surveyor's name:	Survey date:	
Site name:	Site address:	
Site contact person's name and position:	Contact phone number:	
Room names:	Room numbers:	Number of machines in room:

Building #5

Surveyor's name:	Survey date:	
Site name:	Site address:	
Site contact person's name and position:	Contact phone number:	
Room names:	Room numbers:	Number of machines in room:

Building #6

Surveyor's name:	Survey date:	
Site name:	Site address:	
Site contact person's name and position:	Contact phone number:	
Room names:	Room numbers:	Number of machines in room:

Buffing/Polishing Machine Survey

Machine Owner:	Machine Site:
Surveyor's Name:	Date of Survey:
Supervisors Name:	Shop name & #:

Manufacturer: Baldor Clausing Craftsman Delta General
 Jet Powermatic Rockwell Other _____

Model #:	Serial #:
----------	-----------

Common Electrical Questions		Y	N	N/A
Is there an emergency-stop switch at each operator's position?				
Is there power-outage protection to prevent automatic restart after a power failure?				
Is the machine hardwired?				
If hardwired, does the machine have a lockable disconnect or means to properly be locked out?				
Are all electrical components in good repair? ie: plug, cord, connections				
Voltage:	Full load amps:			
Horsepower:	# of phases:			
If machine can be wired for 115v or 220v, look at plug to verify what it is currently wired for and only write down the actual electrical.				

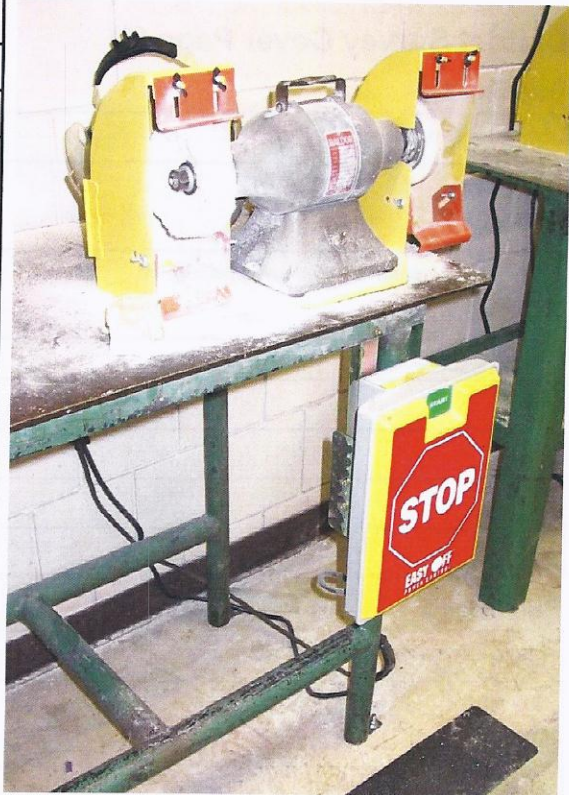

Please take a minimum of 4 pictures for each machine. One from each of the 4 sides from a distance to show the entire machine and its mount from the floor to the top of the machine and an additional close-up picture of each deficiency.

Please explain all 'No' responses in the notes section below in detail	Y	N	N/A
1. Is the machine firmly anchored to prevent tipping or movement during use?			
2. Is there a high-friction coating on the floor at the operator's position(s)?			
3. Are all machine guards color-coded yellow?			
4. Are the edges of accessible pulleys color-coded orange?			
5. Are all pinch point areas color-coded orange?			
6. Are all OEM parts in place and operational?			
7. Are the set screws that hold the mandrel flush with the shaft surface?			
8. Is the buffer enclosed by an exhaust and enclosure hood?			
9. Does the buffer shaft protrude beyond the nut over 1/2 the diameter of the shaft? (list shaft length & diameter below)			

Notes:

Drill Press Survey			
Machine Owner:	Machine Site:		
Surveyor's Name:	Date of Survey:		
Supervisors Name:	Shop name & #:		
Manufacturer: __ Baldor __ Clausing __ Craftsman __ Delta __ General __ Jet __ Powermatic __ Rockwell __ Other _____			
Model #:	Serial #:		
Common Electrical Questions	Y	N	N/A
Is there an emergency-stop switch at each operator's position?			
Is there power-outage protection to prevent automatic restart after a power failure?			
Is the machine hardwired?			
If hardwired, does the machine have a lockable disconnect or means to properly be locked out?			
Are all electrical components in good repair? ie: plug, cord, connections			
Voltage:	Full load amps:		
Horsepower:	# of phases:		
If machine can be wired for 115v or 220v, look at plug to verify what it is currently wired for and only write down the actual electrical.			



Please take a minimum of 4 pictures for each machine. One from each of the 4 sides from a distance to show the entire machine and its mount from the floor to the top of the machine and an additional close-up picture of each deficiency.

Please explain all 'No' responses in the notes section below in detail	Y	N	N/A
1. Is the machine firmly anchored to prevent tipping or movement during use?			
2. Is there a high-friction coating on the floor at the operator's position(s)?			
3. Are all machine guards color-coded yellow?			
4. Are the edges of accessible pulleys color-coded orange?			
5. Are all pinch point areas color-coded orange?			
6. Are all OEM parts in place and operational?			
7. Is a chip shield installed to protect the operator from chips?			
8. Are the pulleys, belts, and shafts fully enclosed by a power transmission guard?			
9. Are all speed-control handles and knobs installed?			
10. Are all spindle-control handles and knobs installed and secure to the shaft and hub?			
11. Does the spindle/chuck return to start position without assistance?			
12. Is a spring-loaded chuck key available? (if no, list below the chuck key size located on the existing chuck key or list the make and model of the chuck)			
Notes:			

Pedestal or Bench Grinder Survey				
Machine Owner:	Machine Site:			
Surveyor's Name:	Date of Survey:			
Supervisors Name:	Shop name & #:			
Manufacturer: __ Baldor __ Clausing __ Craftsman __ Delta __ General __ Jet __ Powermatic __ Rockwell __ Other _____				
Model #:	Serial #:			
Common Electrical Questions		Y	N	N/A
Is there an emergency-stop switch at each operator's position?				
Is there power-outage protection to prevent automatic restart after a power failure?				
Is the machine hardwired?				
If hardwired, does the machine have a lockable disconnect or means to properly be locked out?				
Are all electrical components in good repair? ie: plug, cord, connections				
Voltage:	Full load amps:			
Horsepower:	# of phases:			
If machine can be wired for 115v or 220v, look at plug to verify what it is currently wired for and only write down the actual electrical.				



Please take a minimum of 4 pictures for each machine. One from each of the 4 sides from a distance to show the entire machine and its mount from the floor to the top of the machine and an additional close-up picture of each deficiency.

Please explain all 'No' responses in the notes section below in detail	Y	N	N/A
1. Is the machine firmly anchored to prevent tipping or movement during use?			
2. Is there a high-friction coating on the floor at the operator's position(s)?			
3. Are all machine guards color-coded yellow?			
4. Are the edges of accessible pulleys color-coded orange?			
5. Are all pinch point areas color-coded orange?			
6. Are all OEM parts in place and operational?			
7. Are peripheral guards installed?			
8. Are the tool rests installed & located at or above the shaft centerline and no more than 1/8" from the stone?			
9. Are the tongue guards installed and no more than 1/4" from the stone?			
10. Are the work lights, if installed, protected from impact and breakage from all angles?			
11. Are eye shields installed?			
13. Is the dust collect system connected to a bucket or a hose or whole shop system?			
14. Is a brake system installed to stop the grinding wheels within 1 minute of shut off?			

Notes:

Wood Turning Lathe Survey				
Machine Owner:	Machine Site:			
Surveyor's Name:	Date of Survey:			
Supervisors Name:	Shop name & #:			
Manufacturer: __Baldor __Clausing __Craftsman __Delta __General __Jet __Powermatic __Rockwell __Other _____				
Model #:	Serial #:			
Common Electrical Questions		Y	N	N/A
Is there an emergency-stop switch at each operator's position?				
Is there power-outage protection to prevent automatic restart after a power failure?				
Is the machine hardwired?				
If hardwired, does the machine have a lockable disconnect or means to properly be locked out?				
Are all electrical components in good repair? ie: plug, cord, connections				
Voltage:	Full load amps:			
Horsepower:	# of phases:			
If machine can be wired for 115v or 220v, look at plug to verify what it is currently wired for and only write down the actual electrical.				



Please take a minimum of 4 pictures for each machine. One from each of the 4 sides from a distance to show the entire machine and its mount from the floor to the top of the machine and an additional close-up picture of each deficiency.

Please explain all 'No' responses in the notes section below in detail	Y	N	N/A
1. Is the machine firmly anchored to prevent tipping or movement during use?			
2. Is there a high-friction coating on the floor at the operator's position(s)?			
3. Are all machine guards color-coded yellow?			
4. Are the edges of accessible pulleys color-coded orange?			
5. Are all pinch point areas color-coded orange?			
6. Are all OEM parts in place and operational?			
7. Is a chip shield that extends over the entire length of the bed way installed?			
8. Are the pulleys, belts, and shafts fully enclosed by a guard?			
9. Is the shaft on the left side of the headstock guarded with a hand wheel or other type of guard?			
Notes:			

Wood Jointer Survey				
Machine Owner:	Machine Site:			
Surveyor's Name:	Date of Survey:			
Supervisors Name:	Shop name & #:			
Manufacturer: __ Baldor __ Clausing __ Craftsman __ Delta __ General __ Jet __ Powermatic __ Rockwell __ Other _____				
Model #:	Serial #:			
Common Electrical Questions		Y	N	N/A
Is there an emergency-stop switch at each operator's position?				
Is there power-outage protection to prevent automatic restart after a power failure?				
Is the machine hardwired?				
If hardwired, does the machine have a lockable disconnect or means to properly be locked out?				
Are all electrical components in good repair? ie: plug, cord, connections				
Voltage:	Full load amps:			
Horsepower:	# of phases:			
If machine can be wired for 115v or 220v, look at plug to verify what it is currently wired for and only write down the actual electrical.				



Please take a minimum of 4 pictures for each machine. One from each of the 4 sides from a distance to show the entire machine and its mount from the floor to the top of the machine and an additional close-up picture of each deficiency.

Please explain all 'No' responses in the notes section below in detail	Y	N	N/A
1. Is the machine firmly anchored to prevent tipping or movement during use?			
2. Is there a high-friction coating on the floor at the operator's position(s)?			
3. Are all machine guards color-coded yellow?			
4. Are the edges of accessible pulleys color-coded orange?			
5. Are all pinch point areas color-coded orange?			
6. Are all OEM parts in place and operational?			
7. Does the Pork Chop guard reliably return to the start position?			
8. Does the Pork Chop guard fully cover the front cutter head?			
9. Are the fence adjustment knobs all present?			
10. Is the unused portion of the cutter head behind the fence fully enclosed by a guard?			
11. Are the belts & pulleys fully enclosed by a guard?			

Notes:

Metal Turning Lathe Survey			
Machine Owner:	Machine Site:		
Surveyor's Name:	Date of Survey:		
Supervisors Name:	Shop name & #:		
Manufacturer: __ Baldor __ Clausing __ Craftsman __ Delta __ General __ Jet __ Powermatic __ Rockwell __ Other _____			
Model #:	Serial #:		
Common Electrical Questions	Y	N	N/A
Is there an emergency-stop switch at each operator's position?			
Is there power-outage protection to prevent automatic restart after a power failure?			
Is the machine hardwired?			
If hardwired, does the machine have a lockable disconnect or means to properly be locked out?			
Are all electrical components in good repair? ie: plug, cord, connections			
Voltage:	Full load amps:		
Horsepower:	# of phases:		
If machine can be wired for 115v or 220v, look at plug to verify what it is currently wired for and only write down the actual electrical.			



Please take a minimum of 4 pictures for each machine. One from each of the 4 sides from a distance to show the entire machine and its mount from the floor to the top of the machine and an additional close-up picture of each deficiency.

Please explain all 'No' responses in the notes section below in detail	Y	N	N/A
1. Is the machine firmly anchored to prevent tipping or movement during use?			
2. Is there a high-friction coating on the floor at the operator's position(s)?			
3. Are all machine guards color-coded yellow?			
4. Are the edges of accessible pulleys color-coded orange?			
5. Are all pinch point areas color-coded orange?			
6. Are all OEM parts in place and operational?			
7. Is there a travel guard (cross slide shield) installed that serves as a chip shield?			
8. Is a chuck shield installed that protects the operator from the rotating parts of the chuck?			
9. Is a spring-loaded chuck wrench available? (If no, list chuck wrench size below)			
10. If a drill press style chuck is available, is there a spring-loaded chuck key? (If no, list below the chuck key size located on the existing chuck key or list the make and model of the chuck)			
11. Are the pulleys, belts, and shafts fully enclosed by a power transmission guard?			

Horizontal Milling Machine Survey	
Machine Owner:	Machine Site:
Surveyor's Name:	Date of Survey:
Supervisors Name:	Shop name & #:
Manufacturer: __Baldor __Clausing __Craftsman __Delta __General __Jet __Powermatic __Rockwell __Other _____	
Model #:	Serial #:
Common Electrical Questions	Y N N/A
Is there an emergency-stop switch at each operator's position?	
Is there power-outage protection to prevent automatic restart after a power failure?	
Is the machine hardwired?	
If hardwired, does the machine have a lockable disconnect or means to properly be locked out?	
Are all electrical components in good repair? ie: plug, cord, connections	
Voltage:	Full load amps:
Horsepower:	# of phases:
If machine can be wired for 115v or 220v, look at plug to verify what it is currently wired for and only write down the actual electrical.	

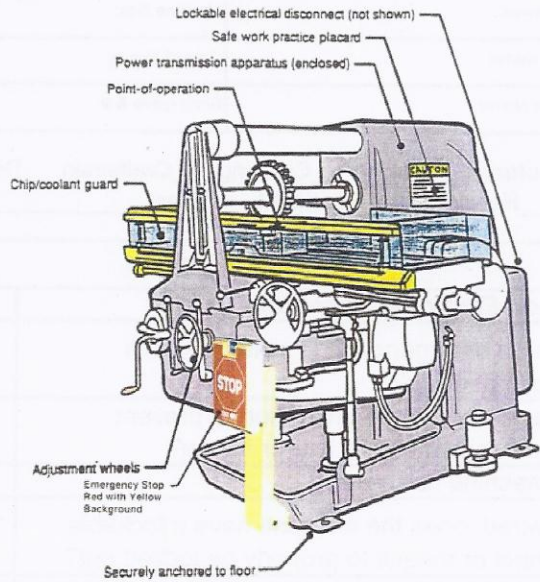

Please take a minimum of 4 pictures for each machine. One from each of the 4 sides from a distance to show the entire machine and its mount from the floor to the top of the machine and an additional close-up picture of each deficiency.

Please explain all 'No' responses in the notes section below in detail	Y	N	N/A
1. Is the machine firmly anchored to prevent tipping or movement during use?			
2. Is there a high-friction coating on the floor at the operator's position(s)?			
3. Are all machine guards color-coded yellow?			
4. Are the edges of accessible pulleys color-coded orange?			
5. Are all pinch point areas color-coded orange?			
6. Are all OEM parts in place and operational?			
7. Are the pulleys, belts, and shafts fully enclosed by a power transmission guard?			
8. Is a shield installed that protects the operator from chips and broken cutters?			
9. Are the work lights, if installed, protected from impact and breakage from all angles?			

Notes:

Vertical Metal Cutting Mill Survey				
Machine Owner:	Machine Site:			
Surveyor's Name:	Date of Survey:			
Supervisors Name:	Shop name & #:			
Manufacturer: __Baldor __Clausing __Craftsman __Delta __General __Jet __Powermatic __Rockwell __Other _____				
Model #:	Serial #:			
Common Electrical Questions		Y	N	N/A
Is there an emergency-stop switch at each operator's position?				
Is there power-outage protection to prevent automatic restart after a power failure?				
Is the machine hardwired?				
If hardwired, does the machine have a lockable disconnect or means to properly be locked out?				
Are all electrical components in good repair? ie: plug, cord, connections				
Voltage:	Full load amps:			
Horsepower:	# of phases:			
If machine can be wired for 115v or 220v, look at plug to verify what it is currently wired for and only write down the actual electrical.				

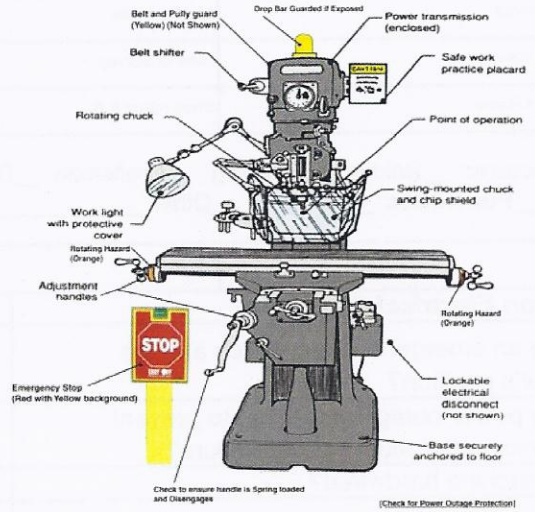

Please take a minimum of 4 pictures for each machine. One from each of the 4 sides from a distance to show the entire machine and its mount from the floor to the top of the machine and an additional close-up picture of each deficiency.

Please explain all 'No' responses in the notes section below in detail	Y	N	N/A
1. Is the machine firmly anchored to prevent tipping or movement during use?			
2. Is there a high-friction coating on the floor at the operator's position(s)?			
3. Are all machine guards color-coded yellow?			
4. Are the edges of accessible pulleys color-coded orange?			
5. Are all pinch point areas color-coded orange?			
6. Are all OEM parts in place and operational?			
7. Are the pulleys, belts, and shafts fully enclosed by a power transmission guard?			
8. Is the draw bar properly covered?			
9. Is a shield installed that protects the operator from chips and broken cutters?			
10. Are the work lights, if installed, protected from impact and breakage from all angles?			
11. If a drill press style chuck is available, is there a spring-loaded chuck key? (If no, list below the chuck key size located on the existing chuck key or list the make and model of the chuck)			
Notes:			

Power Hydraulic Press Survey			
Machine Owner:	Machine Site:		
Surveyor's Name:	Date of Survey:		
Supervisors Name:	Shop name & #:		
Manufacturer: __Baldor __Clausing __Craftsman __Delta __General __Jet __Powermatic __Rockwell __Other _____			
Model #:	Serial #:		
Common Electrical Questions	Y	N	N/A
Is there an emergency-stop switch at each operator's position?			
Is there power-outage protection to prevent automatic restart after a power failure?			
Is the machine hardwired?			
If hardwired, does the machine have a lockable disconnect or means to properly be locked out?			
Are all electrical components in good repair? ie: plug, cord, connections			
Voltage:	Full load amps:		
Horsepower:	# of phases:		
If machine can be wired for 115v or 220v, look at plug to verify what it is currently wired for and only write down the actual electrical.			

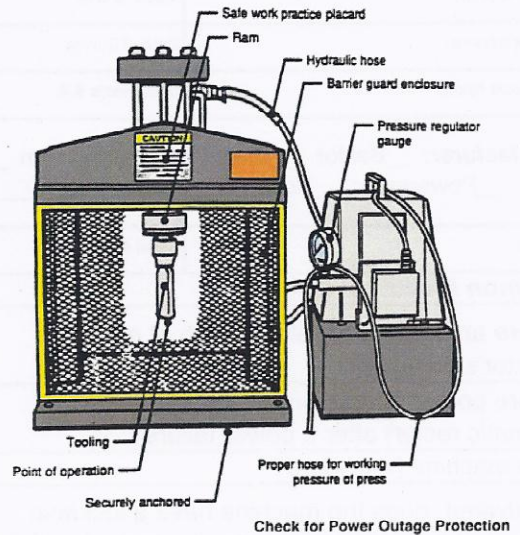

Please take a minimum of 4 pictures for each machine. One from each of the 4 sides from a distance to show the entire machine and its mount from the floor to the top of the machine and an additional close-up picture of each deficiency.

Please explain all 'No' responses in the notes section below in detail	Y	N	N/A
1. Is the machine firmly anchored to prevent tipping or movement during use?			
2. Is there a high-friction coating on the floor at the operator's position(s)?			
3. Are all machine guards color-coded yellow?			
4. Are the edges of accessible pulleys color-coded orange?			
5. Are all pinch point areas color-coded orange?			
6. Are all OEM parts in place and operational?			
7. Is the pressure regulator and gauge working properly?			
8. Is the point of operation properly guarded to prevent parts from being ejected from the press?			
9. Does the machine have the proper hose for working pressure of the press?			

Notes:

Manual Hydraulic Press Survey				
Machine Owner:		Machine Site:		
Surveyor's Name:		Date of Survey:		
Supervisors Name:		Shop name & #:		
Manufacturer: __ Baldor __ Clausing __ Craftsman __ Delta __ General __ Jet __ Powermatic __ Rockwell __ Other _____				
Model #:		Serial #:		
Common Electrical Questions		Y	N	N/A
Is there an emergency-stop switch at each operator's position?				
Is there power-outage protection to prevent automatic restart after a power failure?				
Is the machine hardwired?				
If hardwired, does the machine have a lockable disconnect or means to properly be locked out?				
Are all electrical components in good repair? ie: plug, cord, connections				
Voltage:	Full load amps:			
Horsepower:	# of phases:			
If machine can be wired for 115v or 220v, look at plug to verify what it is currently wired for and only write down the actual electrical.				

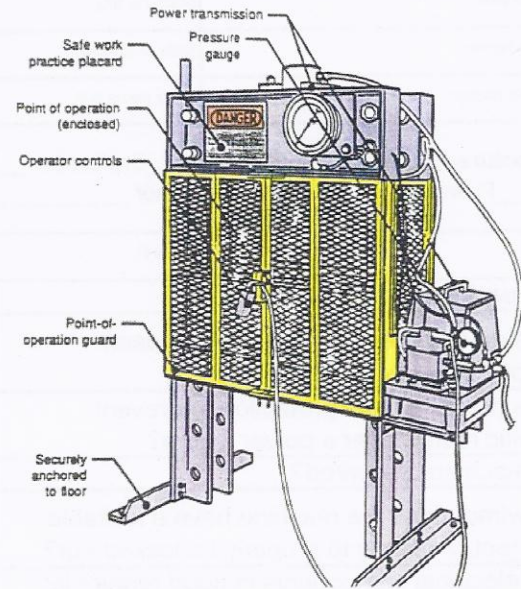

Please take a minimum of 4 pictures for each machine. One from each of the 4 sides from a distance to show the entire machine and its mount from the floor to the top of the machine and an additional close-up picture of each deficiency.

Please explain all 'No' responses in the notes section below in detail	Y	N	N/A
1. Is the machine firmly anchored to prevent tipping or movement during use?			
2. Is there a high-friction coating on the floor at the operator's position(s)?			
3. Are all machine guards color-coded yellow?			
4. Are the edges of accessible pulleys color-coded orange?			
5. Are all pinch point areas color-coded orange?			
6. Are all OEM parts in place and operational?			
7. Is the point of operation properly guarded to prevent parts from being ejected from the press?			

Notes: